



# Andover Continuum

## Family of Security Products

TAC goes well beyond traditional security systems with our integrated approach. By combining everything from video monitoring to access control to intrusion detection, we deliver a more complete security understanding.

### POWERFUL SYSTEM-WIDE CONTROL FROM WORKSTATIONS OR THE WEB

Andover Continuum gives you a single view of all your security systems, through user-friendly workstations or over secure web links. For example, you can create reports for any event, with details down to the exact access point, so you can troubleshoot security breaches more effectively, or recognize and correct faulty equipment more rapidly. You can also connect security systems with personnel information, so you know exactly who accessed what areas and when.

With a single picture of security, and one view of all systems, you can monitor, control and secure your facilities like never before:

- **Access Control** – protect every access point in your building
- **Intrusion Detection** – detect early, respond rapidly
- **Digital Video Management** – the latest technology, seamlessly integrated

### RESPOND IMMEDIATELY TO NEW THREATS

In today's world, the security risk at a site may change in an instance. TAC has designed Andover Continuum to act swiftly in the event of heightened risk. We have added features such as "Area Lockdown" and "Conditional Level-Based Access Rights" to provide the most secure environment in times of elevated threats. Area Lockdown lets you quickly seal off areas in an emergency. You can disable card readers and exit requests with a simple click of a graphic or an automatic program response. First responders can still gain access with "executive privilege". Condition Level automatically reduces the access rights of personnel during a high risk period. With the ability to assign up to 255 condition or "threat levels", the Andover Continuum system can be configured for any situation. Government security warning systems such as the U.S. Homeland Security Threat Levels may be linked to the Andover Continuum system to automatically set conditional levels at your site.

### SECURE, ENCRYPTED COMMUNICATIONS

TAC understands that securing a facility is more than securing doors and gates; the security system itself must be secure from hackers to protect the privacy of the personnel who utilize the system. The Andover Continuum system not only protects access from computers with user-based security, but also protects the information as it is transmitted down the wire with encryption. To encrypt communications, TAC employs a combination of technologies, including Internet Protocol Security (IPsec) with Internet Key Exchange Protocol (IKE) to ensure tamper-proof communications between Andover Continuum controllers and workstations, and Secure Socket Layer (SSL) to provide secure communications via the Web, using a private key to encrypt data.

- Powerful interfaces for graphics, schedules, trends, reports, alarms, personnel, programming and more
- Monitor live and recorded video from a Digital Video Management System
- Import and synchronize personnel records from HR databases with ease using LDAP or CSV files
- Battery backed storage for up to 480,000 personnel records
- Flash for easy online software updates
- Compatible with Andover Infinity hardware and CyberStation 1.8 and higher software
- Secure 10/100 Ethernet communications via IPsec/IKE Encryption with hardware acceleration for Authentication and Encryption
- Support for Area Lockdown and Condition "Threat" Level based access rights
- Support for Modbus XDrivers
- HSPD-12/FIPS 201 Ready

# Andover Continuum Security Architecture

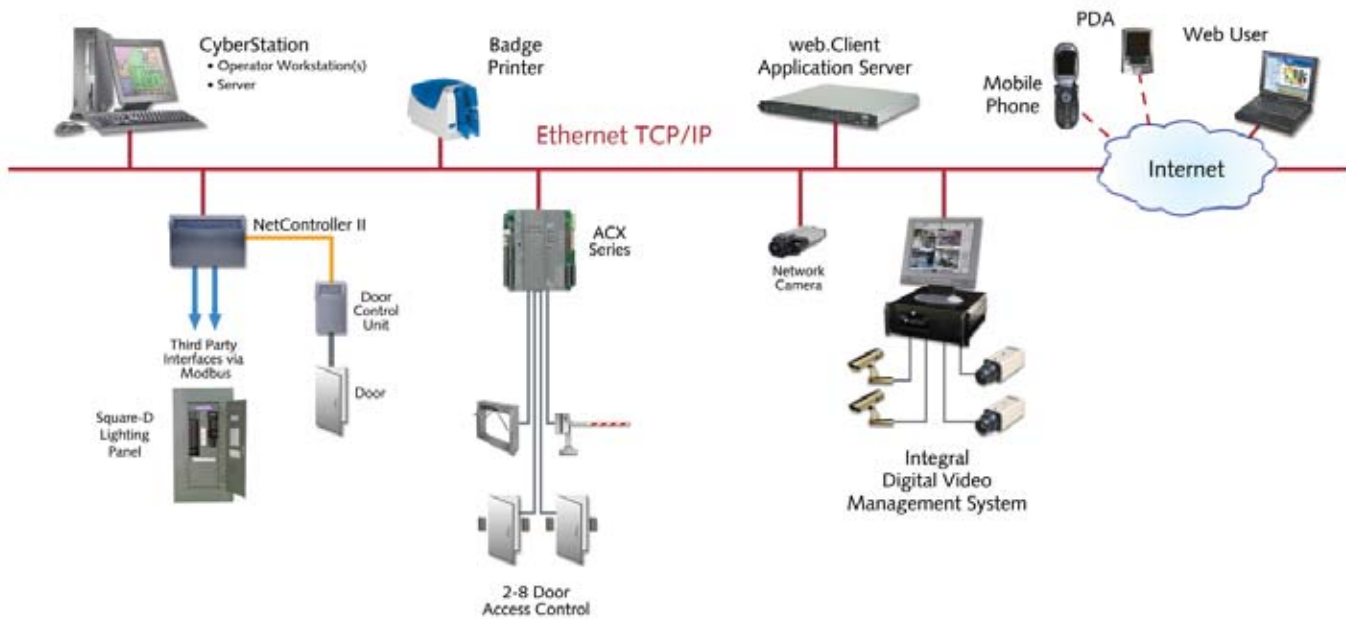

## ARCHITECTURE

The scalable Andover Continuum architecture permits a simple one or two door security system to be expanded to a multi-site installation with millions of doors. Personnel Record scan be entered and badges printed from the same workstation that graphically monitors the site, downloads access rights, and receives alarms and events for instant response and long term storage.

The Andover Continuum access control hardware is available in two form factors:

- **Access Controllers:** These multi-reader controllers store their own personnel records and have their own CPU to make access control decisions. Ranging from 4 to 8 reader models, Access Controllers communicate via the Ethernet to offer a high-performance, high-reliability solution for access control.
- **Access Control I/O Module System:** Add only the readers, supervised inputs and digital outputs that are required. The modules share a common CPU module and may be mounted locally or remotely from the CPU. Each module in the AC-1 series is designed with a single reader input and a variety of supervised inputs and digital outputs. Other I/O modules are available to provide intrusion points or digital alarm outputs.

## DISTRIBUTED OR CENTRALIZED ACCESS CONTROL

When designing an Andover Continuum access control system, you may choose to set up either a distributed system with access modules/controllers at a single door, or a centralized system, with access modules/controllers at a centralize location. Alternatively, you may install the Andover Continuum access control solution with a mix of distributed access modules and central access controllers. This flexibility permits Andover Continuum to be installed in a wide variety of locations.

## CyberStation & web.Client Security Software

As a complete user interface for the Andover Continuum system, CyberStation can be used to commission, configure, program, and monitor every security device, input and output attached to the network. CyberStation provides true integration of security (access control, intrusion monitoring and digital surveillance) within a single user interface.

### MONITORING, VIDEO INTEGRATION AND REPORTING

When it comes to monitoring and reporting, CyberStation really shines. Its graphics system is fully featured and provides dynamic updates of point values for any object on the system. Schedules, Live Event Views, Reports and other tools can be launched from a graphic which provides quick, easy access to manage your whole system. Monitoring is further enhanced with the video integration features allowing the user to view live and recorded video from a "Video Layout" matrix. CyberStation's graphical reports can display raw log data in many output formats: html text reports, scalable vector graphic (SVG) bar, pie and line charts, or as an Adobe® Acrobat® PDF file. Furthermore, data can be represented statistically (e.g., the top 10 alarms, most commonly used doors). Reports can be run manually or executed on an alarm or schedule event and emailed to a predefined recipient list.

### ALARMS & EVENTS

CyberStation serves as a powerful engine for collecting alarms and events and taking automatic actions (e.g., display the active alarm view, send as email, play an audio clip, launch a graphic, launch a live video layout). Users may be required to add a comment and sign off on alarm acknowledgments as an electronic signature of their action.

### PROGRAMMING

CyberStation contains a rich editor for programming Andover Continuum controllers with the Plain English (PE) programming language. This flexible environment allows for the most complex and customer-specific sequences to be programmed.

### SIMPLIFIED PERSONNEL DATA ENTRY AND BADGE CREATION

Personnel records are easily managed using custom forms that require minimal training. Since the forms are customizable, you can be certain that these records are managed in a manner consistent with your organization. Assignment of access rights is as simple as assigning a record to a "Profile" that contains the valid areas and schedules for that group. To simplify data entry CyberStation can import data using LDAP or CSV files. When you are ready to create a physical badge, CyberStation is equipped with a full function badge creation package that captures photos, signatures and fingerprints, and prints to a wide range of badge printers.

### WEB.CLIENT BROWSER INTERFACE

web.Client extends the Andover Continuum system to the web. Using the same database as CyberStation, web.Client gives the operator the freedom to access the Andover Continuum system from anywhere on the network or over Internet. Many of CyberStation's editors and features are available in web.Client. web.Client even uses the same graphics as CyberStation so there is no need to create or convert a specific graphic for web use. Furthermore, ad hoc reports may be created while connected to Andover Continuum via web.Client.

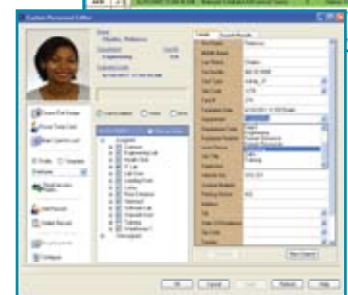
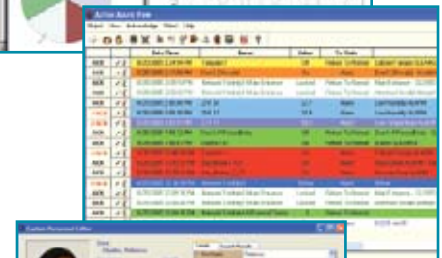
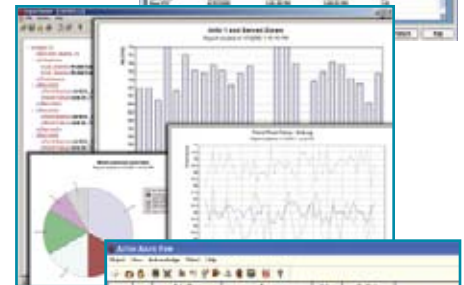

## ACX Series of Access Controllers

The ACX Series controllers are the industry's most powerful all-in-one access controllers designed for both critical government and public sector security applications. These Andover Continuum controllers are just as attractive for one to eight reader installations.

### ONBOARD I/O FOR ACCESS CONTROL

TAC understands that not all security installations are the same. The ACX Series has been designed with flexibility in mind. There are two base hardware models: the 5720 and the 5740. The 5740 has double the universal inputs, reader inputs, and outputs on-board as the 5720. These models come standard with the following I/O configurations:

ACX Series	Model 5720	Model 5740
Universal Inputs	6	12
Reader Inputs	4	8
Tamper Input	1	1
Digital Lock Outputs	2	4

The ACX is designed to support both entry and egress readers while supplying +5 or +12 VDC to each reader.

### 128 MB OF DYNAMIC RAM AND 32 MB OF FLASH MEMORY

Each ACX Series controller comes standard with 32 MB of flash memory and 128 MB of DDR SDRAM. The flash memory is used to preserve 12 MB of application and run-time data. The dynamic RAM is partitioned for dedicated functions: a full 12 MB for applications, 48 MB for personnel records and 8 MB for the operating system. The unused memory is available for future enhancements.

Personnel record data is preserved using on-board batteries that can hold the data for at least 7 days without the use of an external UPS. If the controller has its application stored in flash and power loss lasts longer than what the battery can supply for RAM, the controller will send a message to CyberStation and request that the personnel records automatically be reloaded when the power returns.

### INTERNAL SUPPORT FOR 480,000 PERSONNEL RECORDS

The ACX Series is perfect for large systems. A controller servicing up to 8 areas can hold 480,000 personnel records. With such a large local storage capacity, access decisions can be made swiftly without waiting for validation by a remote server.

### ADVANCED READER INPUTS WITH DEDICATED PROCESSOR

The reader inputs are powered by a dedicated processor allowing the ACX Series controllers to support current and future devices for advanced applications. The ACX Series hardware is ready to support 260-bit encrypted data messages from the reader.

### FULL CREDENTIAL FORMAT SUPPORT FOR 260-BITS

The ACX Series controllers are ready to support a wide range of card formats. Ideal for retrofits, an ACX controller lets you preserve existing cards by accepting standard formats (Weigand, ABA, HID Corporate-1000, CardKey) as well as custom formats (Custom Weigand, Custom ABA). The ACX can support formats up to 260-bits making the ACX Series controllers ready for government installations that must meet HSPD-12 and FIPS 201 standards.

### XP MODULE SUPPORT

Each model supports the use of two xP expansion modules plus an xP-Display unit. The xPBD4 module is ideal for expanding the ACX for special or ADA access to doors. Modules can also be used to provide a cost effective entry reader only solution.



### DIMENSIONAL DRAWING

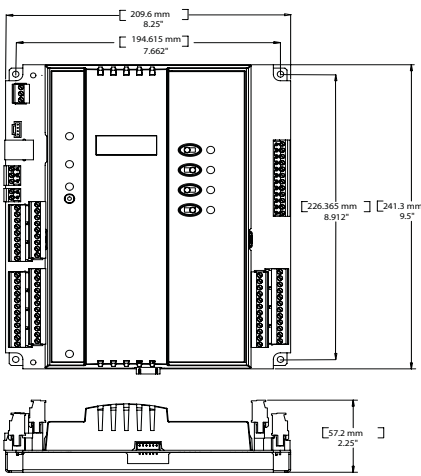

### POWER CONNECTIONS

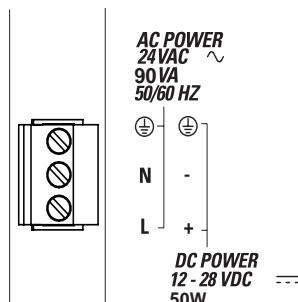

### COMMUNICATIONS

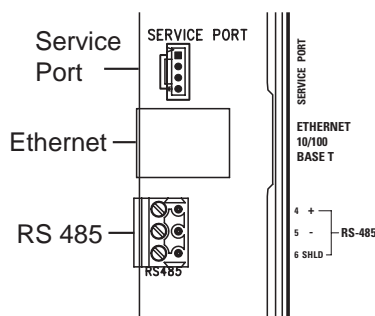

## INPUT CONNECTIONS

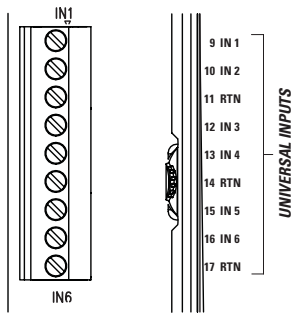

Model 5720

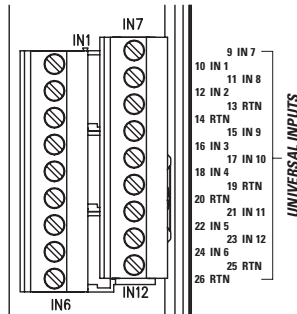

Model 5740

## CARD READER CONNECTIONS

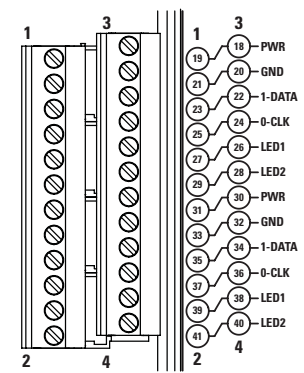

Model 5720

## OUTPUT CONNECTIONS

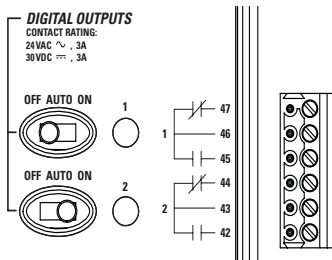

Model 5720

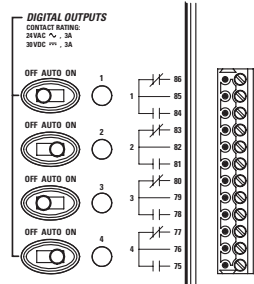

Model 5740

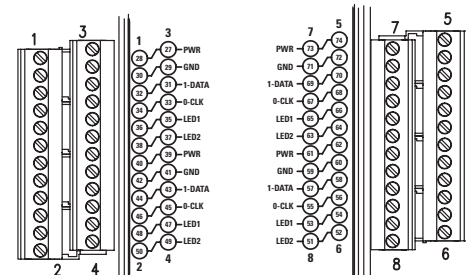

Model 5740

## SPECIFICATIONS

### ELECTRICAL

#### Power

24VAC, 50/60 Hz  
12-28 VDC auto-sensing

#### Power Consumption

90 VA (AC)  
50 W (DC)

### MECHANICAL

#### Dimensions

8.25" W x 9.5" L x 2.25" H  
(209.6 W x 241.3 L x 57.2 H mm)

#### Weight

1.73 lbs. (0.78 kg.)

### BATTERY

#### Internal Battery

NiMH, 3.6 VDC, 800 mAh

#### Battery Backup

Minimum 7 days DDR SDRAM and real-time clock

### COMMUNICATIONS

#### Comm. Error Checking

International Standard CRC 16

#### Ethernet LAN Interface

10/100 Ethernet; ethernet cable with RJ-45 connector.

### CONNECTIONS

#### Power

3-position connector on left side of module for direct connection to a 24 VAC or 12-28 VDC external power source.

#### Ethernet

RJ-45 connector for 10/100 Ethernet

### INPUTS

#### Cabinet Tamper Input

2-pin connector for cabinet tamper switches located on the cabinet door and wall.

#### Universal Inputs

6 (Model 5720) or 12 (Model 5740) universal inputs that can be configured as supervised or general purpose UI.

#### Alarm Inputs

6 (Model 5720) or 12 (Model 5740) supervised inputs. Single or double resistor supervision, series or parallel.

#### Card Readed/Keypad Inputs

4 (Model 5720) or 8 (Model 5740) inputs. Each input can be connected to a card reader, dedicated keypad, or reader/keypad combination.

### CARD READER/KEYPAD

#### Card Reader Type

Wiegand, ABA, or CardKey (jumper selectable)

#### Max Number of Bits/Card

Up to 260 bits/card

#### Card Reader Power

+5 VDC @ 120 mA or  
+12 VDC @ 180 mA  
(jumper selectable)

#### Max Wiring Distance (Reader to ACX)

500 ft. (152.4 m) using 18 AWG  
200 ft. (60.96 m) using 22 AWG

### DOOR OUTPUTS (FORM C RELAY)

#### Door Outputs

2 (Model 5720) or 4 (Model 5740) Form C relays with a manual override switch

#### Output Rating

24 VAC/30 VDC @ 3 A

#### Card Reader LED Output

(2) each, open collector; up to 100 mA

#### Output Protection

5000 V isolation, 270 V MOV on each output

#### Overrides

3-position manual override switch on each output for manual control of relay. LED override status indicator.

### AGENCY LISTINGS

FCC Class A, ICES-003, CE, C-Tick, WEEE, UL/CUL 916  
Pending: UL 294, UL 1076



## xP Expansion Modules

The Andover Continuum xP Expansion I/O Family provides a convenient and cost-effective means to add additional inputs, outputs, or a local display to the ACX Series of access controllers.

Up to two modules plus a local display can be powered directly from any ACX model.

- **xPUI4** – The xPUI4 module allows the addition of 4 Universal Inputs. Each can be configured independently based on your needs for Digital, Temperature, Motion Sensor, or Pulse Counter Inputs, etc., providing built-in flexibility for your different application requirements.
- **xPDO2/xPDO4** – Both the xPDO2 (2 Digital Outputs) and the xPDO4 (4 Digital Outputs) allow the addition of Digital Outputs. Each output has individual manual override switches to select On, Off, or Auto for program control.
- **xPBD4** – The xPBD4 combines the functions of two xP Expansion modules. Similar to the xPUI4, it allows the addition of 4 Universal Inputs and allows for the addition of 4 Digital Outputs (like the xPDO4).

### xP MODULE DIMENSIONAL DRAWING

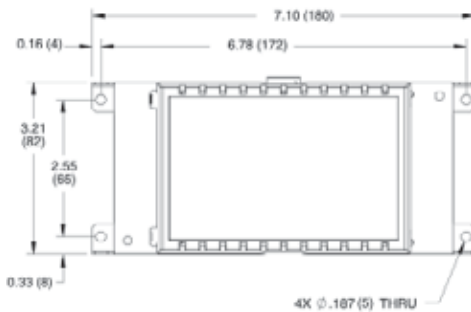

### xP-DISPLAY DIMENSIONAL DRAWING

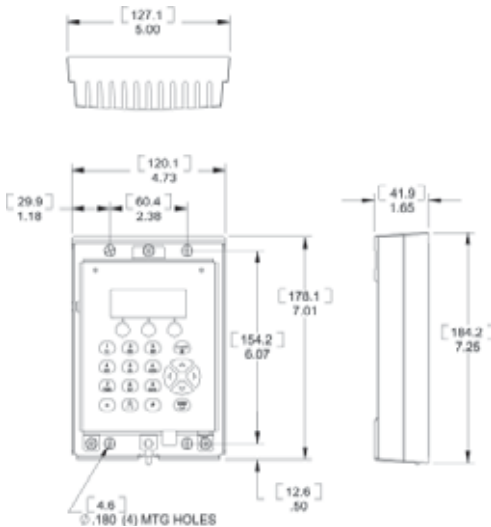

### LOCAL DISPLAY

The local display with keypad (xP-Display) allows for the addition of a fully programmable local display module that can be mounted within 10 feet (3 meters) of the controller. Connected via a ribbon cable, the xP Display easily allows the Operator Interface to be mounted on the door of an enclosure or on a wall below or next to the controller.

### PROGRAMMING

Programming with the Expansion Modules points are treated in the same manner as the built-in I/O points on the controller. Once the points have been configured, they are available for graphics, Plain English™ programming, or for displaying data on the display.

## SPECIFICATIONS

### ELECTRICAL

#### Power

Up to two I/O module and an xP-Display may be connected to a controller. All controllers provide a total of 360 mA of power for the modules. Each module's power consumption is listed below. Reference installation sheet for valid combinations

### MECHANICAL

#### Size

Module: 3.21"H x 7.10"W x 1.60"D  
(82H x 180 W x 41 D) mm

Display: 7.25"H x 5.00"W x 1.65"D  
(184H x 127 W x 42 D) mm

#### Weight

Module: 0.48 lb (0.22 kg)  
Display: 1lb (0.45 kg)

### COMMUNICATIONS

#### Communications Interface

Through built-in Expansion Port on controller

### CONNECTIONS

#### Fixed Terminal Connectors

Reference specific module on previous page for terminal point assignments

#### Input (top)

6-pin shrouded connector

#### Output (bottom)

6-pin shrouded connector

### xPUI4 (UNIVERSAL INPUTS)

#### Points

4 Universal Inputs

#### Power Consumption

50 mA (xPUI4)  
125 mA (xPBD4)

#### Voltage

0-5.115 VDC

#### Input Impedance

10K ohm ref to +5VDC

#### Frequency

4Hz, 50% duty cycling, 1.25 ms pulse width min. (Inputs 1-3)

xPDO2

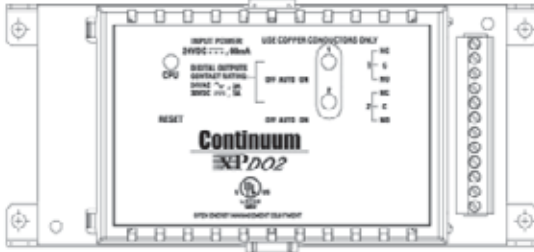

OUTPUTS

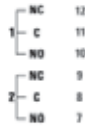

xPDO4

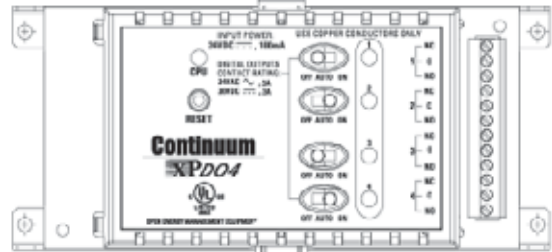

OUTPUTS



xPUI4

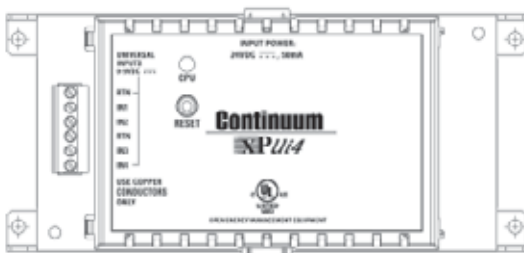

INPUTS

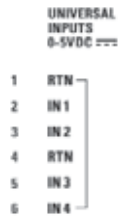

xPBD4

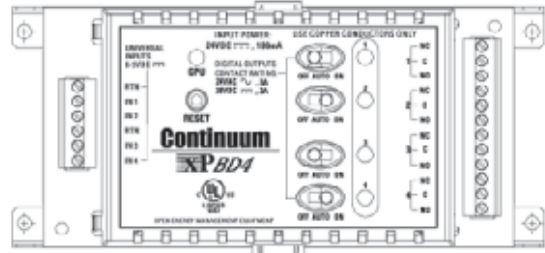

INPUTS

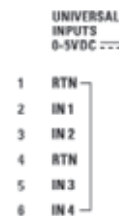

OUTPUTS



## SPECIFICATIONS (continued)

140Hz, 50% duty cycling, 3.57 ms pulse width min. (Input 4)

**Oversoltage Protection**

24 VAC/DC +/- 1500 V transients

**xPDO2/xPDO4/xPBD4 (DIGITAL OUTPUTS)**

**Points**

- 2 Digital Outputs (xPDO2)
- 4 Digital Outputs (xPDO4, xPBD4)

**Type**

2 or 4 single pole single throw (SPST) Form C relays

**Power Consumption**

- 60 mA (xPDO2)
- 100 mA (xPDO4)
- 125 mA (xPBD4)

**Output Rating**

Maximum 3A, 24 VAC/VDC, +/- 1500 V transients (tested according to EN61000-4-4)

**Output Accuracy**

0.1 sec for pulse width modulation

**Output Overrides**

Each Output is equipped with a manual override switch. Software feedback of the switch position is provided, for display and alarming

**AGENCY LISTINGS**

UL/CUL 916, FCC CFR 47 Part 15, ICES-003, EN55022, AS/NZS 3548, Class A, CE

# NetController II CPU Module

The Andover Continuum NetController II is a redesigned version of the NetController, a high-powered Central Processing Unit (CPU) module and network manager for the Andover Continuum intelligent building system. With its 128 MB, 32 MB flash, and four programmable communications ports (including an interface to Infinity's Infinet distributed controllers), the NetController II provides a total solution for facility-wide network communications and information management. Of the total 128 MB memory, 12 MB is allocated for application and run-time data and 48 MB for personnel records.

The NetController II is compatible with Andover Continuum CyberStation software version 1.8 and higher, and includes features such as network security, condition level, area lockdown, and email.

## 128 MB OF DYNAMIC RAM AND 32 MB OF FLASH MEMORY

Each NetController II comes standard with 32MB of flash memory and 128MB of dynamic RAM. The flash memory is used to preserve 12MB of application and run-time data. The dynamic RAM is partitioned for dedicated functions: a full 12MB for applications, an amazing 48MB for Personnel records, and 8MB are reserved for the operating system. Personnel record data is preserved using on-board batteries that can hold the data for at least 7 days without the use of an external UPS.

If the controller has its application stored in flash and power loss lasts longer than what the battery can supply power for RAM, the controller will send a message to CyberStation and request that the personnel records automatically be reloaded.

## INTERNAL SUPPORT FOR 218K TO 480K PERSONNEL RECORDS

The NetController II is perfect for large systems. A controller servicing up to 8 areas can hold 480,000 personnel records and a controller with 32 areas will store 218,000 records. Which such a large local storage capacity, access decisions can be made swiftly without waiting for validation by a remote server.

## HIGH-SPEED COMMUNICATION

The NetController II acts as the system coordinator, providing integrated global control and monitoring, history logging, and local and remote logging for both the Andover Continuum I/O modules and the RS-485 Infinet controllers that control your individual building services — heating, ventilation, air conditioning, lighting, access control, and more. The NetController II communicates with up to 32 Andover Continuum I/O modules via Andover LON communications over a choice of RS-485 or free topology bus media. The NetController II supports expansion of up to two Infinet networks. Each Infinet network can contain 127 Infinet controllers and up to 31 Infinet ACX series access controllers or DCX 250 Infinet display controllers.

An Ethernet port also allows the NetController II to communicate with other NetControllers and Andover Continuum Workstations over a high-speed 10/100 Mbps Ethernet Local Area Network (LAN) using IP protocol. Andover Continuum workstations are capable of communicating with up to 4 million nodes on Ethernet. The Ethernet network interface is a 10/100 Ethernet with an RJ-45 connector.

The NetController II's flash memory allows you to download software revisions over Ethernet using an Andover Continuum workstation. The flash memory feature eliminates the need to perform EPROM change-outs in the field.



## DIMENSIONAL DRAWING

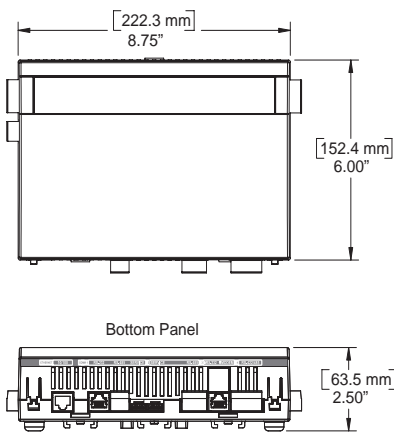

## POWER CONNECTORS

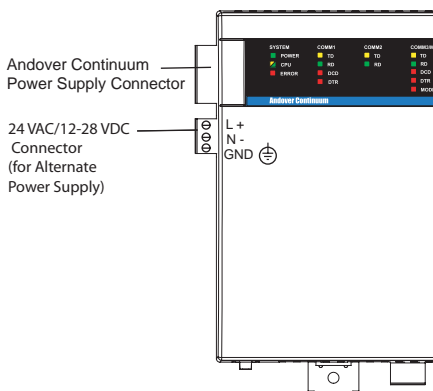

## BOTTOM PANEL

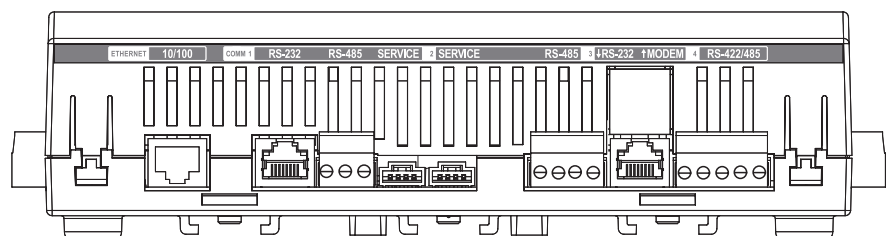

## SERIAL COMMUNICATIONS

The NetController II's four programmable communications ports can be configured as a combination of RS-422, RS-232, or RS-485 interfaces to modems, printers, and third party devices, and up to two Infinet field controller networks.

## OPTIONAL WIRELESS INFINET

The NetController II can also communicate using a wireless mesh network. Simply plug an Andover Continuum Wireless Adapter into one of the Service Ports of the NetController II with wireless compatible firmware to create a wireless mesh network that sends and receives Infinet messages.

# SPECIFICATIONS

## ELECTRICAL

### Power

24VAC, 50/60 Hz  
12-28 VDC auto-sensing

### Power Consumption

10 W

### Real Time Clock

Battery-backed by UPS and internal battery

## MECHANICAL

### Dimensions

8.7" W x 6.00" L x 2.5" H  
(222.3 W x 152.4 L x 63.5 H mm)

### Weight

1.5 lbs. (0.68 kg.)

## COMMUNICATIONS

### Comm. Error Checking

International Standard CRC 16

### Ethernet LAN Interface

10/100 Ethernet; ethernet cable with RJ-45 connector.

### Serial Comm. Interface

Four programmable ports, software configurable as printer, modem, wireless adapter, RoamIO<sub>2</sub>, or third party system. Infinet can be configured on Ports 1 and 2.

Comm1: RS-232, RS-485, Service Port  
Comm2: Service Port, RS-485  
Comm3: RS-232, (optional) Modem (RJ-11 connector)  
Comm4: RS-422 (L-Bus) or RS-485

## ANDOVER PLAIN ENGLISH PROGRAMMING

The Andover Continuum NetController II can be configured to meet the exact requirements of your application using the powerful Andover Plain English programming language. Programs are entered into the NetController II using the Andover Continuum workstation. The NetController II stores and executes the programs. Just as with Infinity, one single language is used system-wide.

### Serial Comm. Interface Speed

Comm1: Baud rates up to 38.4K for RS-232 mode  
Comm3: Baud rates up to 38.4K when configured for RS-232 or internal modem

### Infinet Bus Length

4,000ft. (1,220 m) standard for Infinet using approved shielded, twisted pair, low capacitance cable. Infilink module allows extension to longer distances.

### I/O Bus

ACC-LON communications. Choice of bus media, RS-485 or FTT-10A.

### RS-485 Bus

Communications Speed: 39 K baud  
Bus Length: 2,000 ft. (610 m)  
Bus media: Shielded, twisted-pair cable. 120 ohm termination required at both ends of the ACC-LON network (when modules are mounted remotely)

### FTT-10A Bus

Communications Speed: 78 K baud  
Bus Length: Up to 8858 ft. (2700 m) for Bus Topology  
Up to 1640ft. (500 m) for Free Topology.  
Repeater required for longer distances  
Bus Media: Refer to Echelon FTT-10A Free Topology documentation.

## SOFTWARE CAPABILITIES

The dynamic memory of the NetController II can be allocated for any combination of programs, scheduling, alarming, reporting, and data logging. The object-oriented Andover Plain English language with intuitive keywords provides easy operation and programming. In addition, Andover Plain English's pre-defined and customized functions and powerful math capabilities reduce programming time.

## CONNECTIONS

### Power

5-position plug-in connector on left side of module for direct connection to Andover Continuum power supply module.

3-position connector on left side of module for direct connection to a 24 VAC or 12-28 VDC external power source.

(Both connectors cannot be used at the same time.)

### Ethernet

RJ-45 connector for 10/100 Ethernet

### Printer

RJ-45 connector

### Modem

RJ-11 connector

### I/O Bus

5-position plug-in connector on right side of module for direct connection of up to 32 Continuum I/O modules

## AGENCY LISTINGS

FCC Class A, ICES-003, CE, C-Tick, WEEE, UL/CUL 916  
Pending: UL 294, UL 1076



## NetController II I/O Modules Overview

The Andover Continuum intelligent building system allows you to mix and match various combinations of DIN rail-mounted modules — flexible I/O, CPU and power supply, and your choice of several user interface modules — in a single controller location to meet your building's control and monitoring needs. With the Andover Continuum system, as your network grows, simply add or replace I/O modules as needed.

The Andover Continuum I/O modules feature a sleek, lightweight casing designed for natural convection cooling, and a 3-position front cover for easy access. Built-in quick-release fasteners at the back of each I/O module are provided for DIN rail mounting — no tools required. These fasteners also snap into a locked position for panel mounting. Input and output connectors are located at the bottom of each I/O module and are removable for easy field access and maintenance. All Andover Continuum modules are designed for mounting in an optional NEMA 1-style Andover Continuum enclosure.

The Andover Continuum I/O modules communicate with the Andover Continuum NetController CPU module using Andover LON communications. Like all Andover Continuum modules, the I/O modules slide together via built-in connectors on either side so network expansion is quick and easy. Both power transmission and communication signals feed through these connectors. For added convenience, in applications such as door control or lighting control, a single module or groups of I/O modules can be remotely located and connected using approved cable, and powered from a local power supply. Each I/O module features its own push-button for quick and easy network commissioning.

### COMMUNICATION CHOICES

All Andover Continuum modules are available in either the standard RS-485 or the Free Topology (FTT-10A) media interface. RS-485 is perfect for local mounting applications and is a lower cost media choice. FTT-10A provides increased flexibility and reliability. FTT modules are connected using a twisted-pair cable and can be wired in a bus, star, distributed star, or even a ring topology for added resilience. Note: You cannot mix and match both media types on the same I/O bus.

## SPECIFICATIONS

### MECHANICAL

#### Operating Environment

32–120°F (0 to 49°C), 10–95%RH  
(non-condensing)

#### Size

3.8"W (96.5mm) including connectors  
7.2"H (182.88mm) with mounting clips extended  
6.2"H (157.48mm) with mounting clips closed  
2.5"D (96.5 x 170.2 x 63.5mm)

#### Weight

0.75 lbs (0.34kg)

#### Enclosure Type

UL open class, flammability rating of  
UL94-5V, IP 10

#### Mounting

Mount on DIN rail or wall-mount using  
attached clips.  
Andover Continuum NEMA 1-style  
enclosure available

### COMMUNICATIONS

#### Communications Interface

ACC-LON communications with  
Andover Continuum CPU module  
Choice of RS-485 or FTT-10A interface

#### Comm. Error Checking

International Standard CRC 16

#### RS-485

Communications Speed: 39k baud  
Bus Length: 2,000 ft. (610m)  
Bus Media: Shielded, twisted pair cable  
120Ω termination required at both ends  
of the ACC-LON network (when mod-  
ules are mounted remotely)

#### FTT-10A

Communications Speed: 78k baud  
Bus Length: Up to 8858 ft. (2700m)  
– bus topology  
Up to 1640 ft (500m) – free topology  
Repeater required for longer distances

#### Power/Communications Connections

5-position plug-in connectors on  
left and right sides allow Andover  
Continuum modules to be directly  
connected to each other or remotely  
connected via approved cable

### AGENCY LISTINGS

UL/CUL 916, FCC CFR 47 Part 15,  
ICES-003, EN55022,  
AS/NZS 3548, and VCCI Class A, CE  
UL 864 - (UI-8-10-S, DO-4-R-S,  
DM-20-S, DO-4-R-O-S and  
UI-8-10-10V-S only)  
UL 294 - (UI-8-10, DO-4-R,  
DM-20, AC-1, AC-1Plus, AC-1A,  
UI-8-10-10V and DO-4-R-O only)  
UL-1076 - (UI-8-10, UI-8-10-10V, DO-  
4-R, DO-4-R-O, AC-1, AC-1a,  
and AC-1Plus only)

### I/O MODULE DIMENSIONAL DRAWING

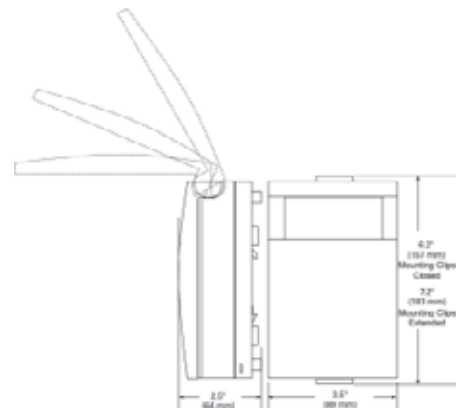

# AC-1 Family of Access Control I/O Modules

## AC-1, AC-1A and AC-1Plus

Andover Continuum offers three access control modules to meet the demands of different access requirements:

- **AC-1:** Use the AC-1 when powering modules from a Andover Continuum power supply. (AC-1 has a 24VDC power input only.) The AC-1 supports Wiegand/Prox cards and 5 V/12 V reader power (switch-selectable).
- **AC-1A:** Use the AC-1A if you are powering modules from a local 12VDC power supply. The AC-1A offers an extended 10-28VDC power input. (Power supply can also power any 12 V prox readers you may be using.) The AC-1A supports Wiegand/Prox cards, and 5 V reader power only.
- **AC-1PLUS:** The enhanced version. Use the AC-1Plus when using mag stripe or Card-key readers, ADA sequences that require extra inputs, special door unlock/door ajar times for disabled persons, and jobs that require reader tamper detection. The AC-1Plus offers an extended 10-28VDC power input (power supply can also power 12 V prox readers), and supports 5 V reader power only.

### AC-1 AND AC-1A:

Both the AC-1 and AC-1A provide full I/O for an access controlled door or portal in one compact module. Each can be located near an access controlled door for localized control and reduced wiring costs; or several AC-1 modules can be grouped together and DIN rail-mounted for centralized control.

The AC-1 provides a Wiegand card input for Wiegand swipe and proximity type cards, reading up to 64 bits per card. Reader power is switch-selectable between 5V and 12V to meet most card reader power requirements.

The AC-1A provides a Wiegand card input for Wiegand swipe and proximity type cards, reading up to 64 bits per card. Reader power is 50 mA at 5V. The module itself can be powered by a voltage source that can range from 10-28 VDC.

Each module has two 5 A, Form C relays—one for the door lock and a second for local alarm annunciation. Each output has an integral hand-off-auto switch for manual operation, and software feedback of the switch position.

Up to three supervised alarm inputs can be used for door status contacts, request-to-exit devices, a cabinet tamper switch, or any other two-state or three-state (on/off/trouble) alarm device.

### AC-1PLUS:

The AC-1Plus, Andover Continuum's full-feature access control module, provides full I/O for an access controlled door or portal in one compact module. The AC-1Plus supports multiple card formats, ADA (Alternate Door Access) doors, and multiple reader LED patterns. In addition, built-in reader supervision is provided—one LED will periodically check for voltage, absence of voltage, or shorts, and expose any of these conditions to the user for security purposes. The AC-1Plus can be located near an access controlled door for localized control and reduced wiring costs; or several AC-1Plus modules can be grouped together and DIN rail-mounted for centralized control.

The AC-1Plus provides a Wiegand card input for Wiegand swipe and proximity type cards, reading up to 64 bits per card. The AC-1Plus also supports CardKey cards, reading up to 34 bits per card, and ABA card readers. Card reader power is 50 mA at 5V.

The AC-1Plus has two 5 A, Form C relays — one for the door lock and an auxiliary output for local alarm annunciation, for example. Each output has an integral hand-off-auto switch and software feedback of the switch position.

The AC-1Plus provides five supervised input channels, configurable as an exit request, door switch sensor, ADA exit request, bond sensor, or as a general purpose supervised input point.



### AC-1 CONNECTIONS

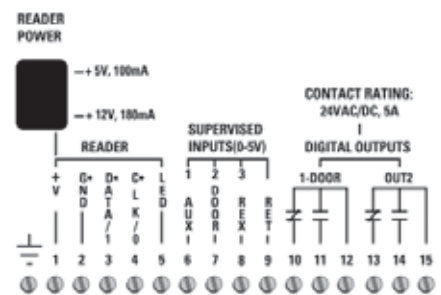

### AC-1A CONNECTIONS

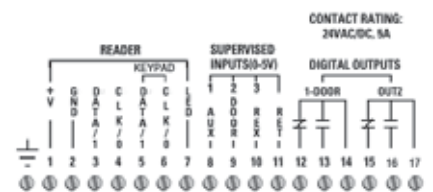

### AC-1PLUS CONNECTIONS

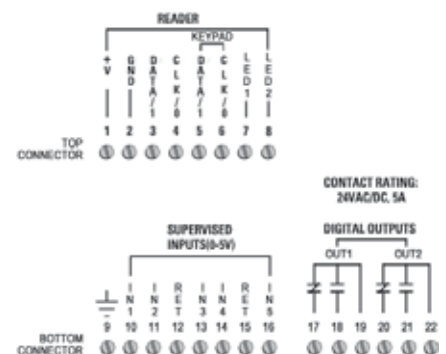

## KEYPAD CONTROL

The AC-1 supports Wiegand output keypads. To simplify installation and reduce wiring costs, the keypad data comes into the module via the reader data lines.

The AC-1A supports Wiegand output keypads. To simplify installation and reduce wiring costs, a combination Wiegand output reader/keypad may be used. In this case, the keypad data comes into the module via the reader data lines. In addition, the AC-1A allows separate wiring of both a Wiegand output keypad and reader.

The AC-1Plus supports Wiegand or ABA output keypads. To simplify installation and reduce wiring costs, a combination Wiegand (or ABA) output reader/keypad may be used. In this case, the keypad data comes into the module via the reader data lines. In addition, the AC-1Plus allows separate wiring of both a Wiegand (or ABA) output keypad and reader.

## ACCESS CONTROL

During normal operation of the AC-1 modules, access decisions are made in the Andover Continuum NetController II CPU, which provides storage for 218,000 to 480,000 "local" personnel records. In addition, the NetController II's event buffer is software-configurable to allow for the most optimized memory usage. If network communications are interrupted, the AC-1 will revert to a programmable degrade mode of operation, providing uninterrupted card access using site codes, card formats, and other degrade mode parameters stored in non-volatile EEPROM such as multiple card types (including custom format) and four site codes per each card type. ADA doors are also supported in degrade mode.

Access can be granted based on site code only, site code plus card, card only, card plus personal ID number (PIN), or keypad only. The door's operating mode can even be changed based on time-of-day or other

events for optimum flexibility through TAC's easy-to-use Andover Plain English programming language. Each keypad can also permit entry of a duress alarm code that can initiate an alarm sequence at any AC-1 controller or at the Andover Continuum workstation.

Time-based anti-passback and entry/egress anti-passback are available to prevent tailgating. Entry/egress anti-passback is system-wide and can be performed by readers located on different AC-1 controllers across the network.

Using Andover Plain English, the AC-1 can also be used for custom access control sequences such as two-man rule, optical turnstile control, and man trap configurations.

## SPECIFICATIONS

### ELECTRICAL

#### Power Consumption

**AC-1:** 2.6 W plus reader power consumption at 24VDC max.

**AC-1A:** 2.0 W at 10-28VDC plus reader power consumption

**AC-1Plus:** 2.2 W at 10-28VDC plus reader power consumption

### INPUTS

#### Card Readers

1

#### Card Reader Type

**AC-1, AC-1A:** Supports Wiegand swipe and proximity readers

**AC-1Plus:** Supports Wiegand, Proximity, CardKey, and ABA readers

#### Maximum Number of bits/Card

**AC-1, AC-1A:**  
64

**AC-1Plus:**  
64 for Wiegand and Proximity  
34 for CardKey

#### Card Reader Power

**AC-1:**  
5 VDC or 12 VDC (switch selectable)

Switch Setting: +5 V  
Output Voltage: +5.20 V  $\pm$ 0.05 V  
Output Current: 120 mA (max.)

Switch Setting: +12 V  
Output Voltage: +12.0 V  $\pm$ 5%  
Output Current: 180 mA (max.)

**AC-1A, AC-1Plus:**  
5 VDC,  $\pm$  3%, 50 mA, Current Limited

#### Distance, Card Reader to AC-1, AC-1A or AC-1Plus

500 ft. max. using 18-ga. wire  
200 ft. max. using 22-ga. wire

#### Alarm Inputs

##### AC-1, AC-1A:

Up to 3 supervised inputs. Single or double resistor supervision, series or parallel

##### AC-1Plus:

5 supervised inputs. Single or double resistor supervision, series or parallel

### OUTPUTS

#### Door Outputs

2 Form C relays

#### Output Rating

5 A @ 24 V AC/DC

#### Overrides

3-position manual override switch on each output for manual control of relay.  
LED override status indicator

#### Override Feedback

Override detection and software feedback provided for each output

#### Reader LED Output

**AC-1:** Open collector; up to 50 mA

**AC-1A:** Open collector; up to 100 mA

**AC-1Plus:** 2 open collector; up to 100 mA. Choice of 3 LED patterns

#### Inputs/Output Connections

**AC-1:** Two-piece, 16-position removable terminal block

**AC-1A:** Two-piece, 18-position removable terminal block

**AC-1Plus:** Removable terminal blocks: (2) 8-position; (1) 6-position

### USER LEDS/SWITCHES

#### Status Indicator LEDS

Power	Power Indicator
Comm	TD Indicator
Override	Common Override Indicator
Status	Service/Wink Indicator
Out1 - Out2	Two Output Status Indicators
+5 V Reader Power	5 V Reader Power Indicator

##### AC-1 Only:

+12 V Reader Power	12 V Reader Power Indicator
--------------------	--------------------------------

#### Switches

Commission  
Reset

## UI-8-10 I/O Module

The UI-8-10, Andover Continuum's universal input module, provides 8 universal inputs, software configurable as voltage, thermistor, digital, or counter point types. Each point can also be configured as a supervised input for security monitoring, providing separate indication of alarm and trouble conditions. This module is a perfect choice for any mix of temperature, pressure, flow, status points, and similar inputs in a control system, with a 0–5 volt input range and 10-bit A/D conversion.

A UI-8-10-10V model is also available for 0–10 volt applications. It provides the identical point type selection, but is equipped with individual voltage divider DIP switches on each input, allowing each to be configured for a 0-10 volt range.



## SPECIFICATIONS

### ELECTRICAL

#### Power Consumption:

0.7 W @ 10-28VDC max.

#### Overload Protection:

0.5 A resettable fuse with transient voltage suppressor (TVS) and reverse polarity protection.

### INPUTS

#### Number of Inputs:

8 Universal inputs; 10 bit resolution

#### Input Types:

Voltage, Thermistor, Digital, Counter, and Supervised

#### Input Protection:

24 V AC/DC allowed to any single input (40V TVS on each input – UI-8-10-10V model only)

#### Input Impedance:

UI-8-10 (0–5V): 5 M $\Omega$  w/pull up disabled; 10 K $\Omega$  w/pull up enabled  
UI-8-10-10V (0–10V): 4.4 K $\Omega$

#### Input Connections:

Two-piece, 13-position removable terminal block

#### Voltage:

UI-8-10 (0–5V)  
Range: 0–5 V  
Resolution: 5 mV  
Accuracy:  $\pm 15$  mV ( $\pm 0.3\%$  FSR)

UI-8-10-10V (0–10V)  
Range: 0–10 V  
Resolution: 10 mV  
Accuracy:  $\pm 15$  mV V ( $\pm 0.4\%$  FSR)

#### Thermistor:

UI-8-10 (0–5V)  
Type: 10 K $\Omega$ , Type III Thermistor  
Range: -30 to 230°F (-34 to 110°C)  
Resolution: 40 to 100°F range (4 to 38°C)  
Accuracy: 40 to 100°F range (4 to 38°C)

UI-8-10-10V (0–10V)  
Type: 10 K $\Omega$ , Type III Thermistor  
Range: -30 to 230°F (-34 to 110°C)  
Resolution: 0.20°F typical (0.11°C typical)  
Accuracy:  $\pm 1.0^\circ\text{F}$  ( $\pm 0.55^\circ\text{C}$ )

#### Digital & Counter:

Input Type: Contact Closure  
Frequency: 4 Hz (max.)  
Pulse Width: 125 ms (min.) (Digital pulse widths are based on Scan Time.)

#### Supervised:

Input Type: Single or Double Resistor Supervision, Parallel or Series Circuit

### USER LEDS/SWITCHES

#### Status Indicator LEDS:

Power	Power Indicator
Comm	TD Indicator
Status	Service/Wink Indicator

#### Push-Button Switches:

Commission	Reset
------------	-------

### UI-8-10 CONNECTIONS

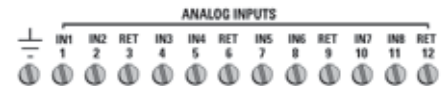



## DO-4-R I/O Module

The DO-4-R, Andover Continuum's digital output module, has four Form C relay outputs, rated at 5 A @ 240 VAC. These versatile outputs make the DO-4-R an excellent choice for switching motor starters and other inductive loads up to 240 VAC, with either two position (on/off) or pulse-width modulation (PWM) control. The PWM feature permits the modulation of valves and dampers to 0.1 second resolution. Two adjacent Form C relay outputs can be combined in software to provide a Tri-state output, for bi-directional control of valves and dampers and other end devices. Metal oxide varistors and 5,000 V isolation on each output ensures reliable noise-free operation.

A DO-4-R-O model with full override capability is also available. Each output has a local hand-off-auto switch, which enables service personnel to override the output. The switch also provides override feedback of the output value for use in troubleshooting or test conditions. A local indicator light for each output displays relay status. Another LED provides override status.

### DO-4-R CONNECTIONS

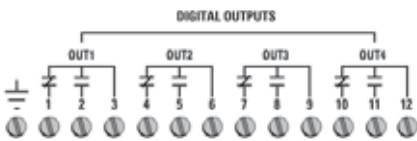

## SPECIFICATIONS

### ELECTRICAL

#### Power Consumption:

2.8 W @ 10--28 VDC max.

#### Overload Protection:

0.5 A resettable fuse with transient voltage suppressor (TVS) and reverse polarity protection

### OUTPUTS

#### DO-4-R:

4 Form C relay outputs

#### DO-4-R-O:

4 Form C relay outputs with overrides

#### Output Rating:

5 A @ 240 VAC; 5 A @ 30 VDC

#### Output Resolution:

0.1 sec. For Pulse Width Modulation (PWM) control

#### Output Protection:

270 V varistors across contacts.  
5000 Vrms isolation @ 60 Hz between relay contacts and relay coil

#### Output Overrides:

3-position manual override switch on each output, with software feedback. LED override status indicator (DO-4-R-O only)

#### Override Feedback:

Override detection and feedback provided for each output

#### Output Connections:

Two-piece, 13-position removable terminal block

### USER LEDS/SWITCHES

#### Status Indicator LEDS:

Power	Power Indicator
Comm	TD Indicator
Override	Common Override Indicator
Status	Service/Wink Indicator
Out1-Out4	Four Output Status Indicators

#### Switches:

Commission  
Reset

## DM-20 I/O Module

The DM-20, Andover Continuum's Digital Input and Output module, provides high density, versatile I/O for many control applications. The DM-20 can control any combination of 20 inputs and outputs.

When coupled with the optional DIO-20 Expansion Board, the DM-20 allows you to mix and match up to 20\* digital inputs and outputs using standard off-the-shelf digital I/O blocks to meet a wide range of applications, including ON-OFF or pulse-width modulation (PWM) control of equipment and for switching inductive loads up to 240VAC. The DM-20 provides 24 VDC power to the DIO-20 via a three-position cable assembly.

\* Actual number of modules depends on the mix of inputs/outputs used. See Andover Continuum I/O System Reference Manual (Rev D or higher) for more information.



## SPECIFICATIONS

### ELECTRICAL

#### Power Consumption

- 0.5 W @ 24VDC max.
- Up to 9 W @ 24 VDC when the DIO-20 is powered from the DM-20

#### External Power Connector

- Three-position removable connector

#### Overload Protection

- 0.5 A resettable fuse with transient voltage suppressor (TVS) and reverse polarity protection for both DM-20 power and DIO-20 power

#### LED Power Supply

- Customer-provided external 5 V power supply when using the DM-20 to drive LEDs

### INPUTS/OUTPUTS

20 total points; user-selectable channel-by-channel as inputs or outputs

#### WITH DIO-20

##### Input Type

- Digital 0–5 VDC

##### Pulse Width

- 125 ms ( min.) (Digital pulse widths are based on Scan Time.)

##### Current

- 10 $\mu$ A

##### Output Type

- Digital Open- collector transistor with series 330 ohm 1/8 W resistor; 15 mA (max.) @ 5 V DC

#### WITHOUT DIO-20

##### Input Type

- 24 VDC logic voltage (DIO-20). Input rating depends on input module(s) selected

##### Pulse Width

- 125 ms ( min.) (Digital pulse widths are based on Scan Time.)

##### Current

- N/A

##### Output Type

- 5 VDC logic voltage. Output range depends on output module selected

#### Output Resolution

- 0.1 sec. For Pulse Width Modulation (PWM) control

#### Output Protection

- Transient voltage suppressor (TVS) and current limiting resistor on each channel

#### Input/Output Connections

- One female 25-pin D-subminiature connector

### USER LEDs/SWITCHES

#### Status Indicator LEDs

- |        |                        |
|--------|------------------------|
| Power  | Power Indicator        |
| Comm   | TD Indicator           |
| Status | Service/Wink Indicator |

#### Switches

- Commission
- Reset

### DM-20 CONNECTIONS

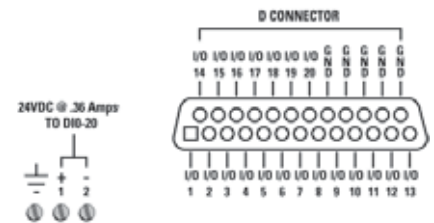



## LO-2 I/O Module

The LO-2, Andover Continuum's lighting control module, can control 2 high voltage lighting circuits, using externally mounted GE RR7 or RR9 lighting relays, rated for 20 A @ 277 VAC (347 VAC option for Canada). These relays are connected to the LO-2 via two three foot, 5-conductor wires provided. The RR9 relay provides status feedback of the relay position, using a built-in pilot contact. The RR7 relay provides control of the circuit with no feedback. An on-board status LED for each output is provided when RR9 relays are used, as well as pilot light voltage for wall switches that have status indication. External 28 VAC is required to power the GE relays. This same transformer can power the LO-2 when the module is located remotely.

An LO-2-O model, with on-board momentary override toggle switches, is also available.

### EXTERNAL OVERRIDE CAPABILITIES

Two Class II low voltage manual override inputs, one for each relay output, are provided for override capabilities. These inputs directly control the lighting relays, independent of any schedule or program. Wall switches, occupancy sensors, or a combination of both may be wired to these inputs.

### LO-2 CONNECTIONS

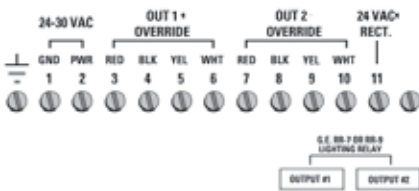

### LIGHTING CONTROL

The LO-2 can be coupled with Andover Continuum's programmable input modules to provide flexible lighting control strategies such as:

- Outdoor Lighting Control with a Photocell
- Daylight Control
- After-Hours Lighting Usage with Card Swipe Readers
- Adjustable Override Time with Flick Warning
- Cleaning Crew Override
- Data Logging and Reporting
- Run time Analysis, including Accumulated On-Time and Percentage On-Time
- Tenant Billing Reports
- Custom Control Strategies

These programs can be easily modified to fit the exact needs of your project.

## SPECIFICATIONS

### ELECTRICAL

#### Power Consumption:

0.4 W @ 24 VDC max. Consumes no DC power when external AC power is present

#### External AC Power:

28 VAC powers both module and lighting relays; can also power the LO-2 module when mounted remotely

#### External Transformer:

40 VA transformer provides power for up to 5 LO-2 modules (10 GE relays and associated devices)

#### Overload Protection:

DC: 0.5 A resettable fuse with transient voltage suppressor (TVS) and reverse polarity protection. AC: 0.5 A resettable fuse with MOV

### INPUTS

#### Inputs:

2 Class II Low Voltage override inputs, providing direct control of lighting relays

#### Input Protection:

Transient voltage suppressors (TVS) with reverse polarity protection

### OUTPUTS

#### Output Type:

2 pulsed lighting control outputs compatible with externally mounted GE RR7 or RR9 relays

#### Output Rating (Lighting Relay):

Lamp Load – 20 A Tungsten Filament @125 VAC  
Resistive Load – 20 A ballast @ 277 VAC (@347 VAC, Canada)  
Motor Load – 0.5 HP @ 110-125 VAC  
0.5 HP @ 220-277 VAC  
(0.5 HP @ 347 VAC, Canada)

#### Pilot Contact Rating (RR9 only):

1 A @ 24 VAC, isolated

#### Output Feedback:

RR9 relays have LED status indication and software feedback for relay status

#### Output Protection:

Transient voltage suppressors (TVS) on outputs. GE relays provide isolation

#### Overrides:

Momentary override toggle switches (LO-2-O model only)

#### AC Power/External Override Input

#### Connections:

Two-piece, 12-position removable terminal block

#### Lighting Relay Connections:

5-position male connector accepts standard GE female plug-in connector. (Two 3-foot, 5-conductor wires with female connectors provided. Wires color-coded to match GE relays.)

### USER LEDs/SWITCHES

#### Status Indicator LEDs:

Power	Power Indicator
Comm	TD Indicator
Status	Service/Wink Indicator
Out1-Out2	Two Output Status Indicators (RR-9 only)
24 VAC	External 24-30 VAC Indicator

#### Switches:

Commission  
Reset

## VT-1 I/O Module

The Andover Continuum VT-1 Interactive Voice Response (IVR) module provides users with easy-to-use remote data entry capabilities for their Andover Continuum system using the familiar touch-tone keypad on any North American standard or cellular telephone. The VT-1 also allows spoken messages to be pre-recorded to inform the user of current system conditions and/or to prompt the user for additional input.

The VT-1 can be used, for example, to change building setpoints or schedules; arm or disarm alarms; unlock doors; request status or determine operating conditions of equipment; and to report alarm or event conditions or history.

The VT-1 provides 10 built-in prompt messages and 50 pre-recorded vocabulary words, which can be used individually or combined to form phrases and sentences. In addition, up to 50 custom messages (up to 3.5 minutes total) can be pre-recorded, played, and erased in the VT-1's Message Management Mode—all over the telephone!



## SPECIFICATIONS

### ELECTRICAL

**Power Consumption:**

1.5 W @ 24 VDC max.

**Overload Protection:**

0.5 A resettable fuse with transient voltage suppressor (TVS) and reverse polarity protection

### INPUTS/OUTPUTS

**Phone Line Connections:**

1 RJ-11 connector with SIDAC and resettable telecom fuses

### USER LEDS/SWITCHES

**Status LEDS:**

- Power
- Communications
- Service/Wink indicator
- Record mode
- Play mode
- Erase mode
- Ring
- Off-hook

**Switches:**

- Commission
- Reset

Note: VT-1 approved for use in North American phone systems only.

## LD-1 Local Display Module



The Andover Continuum LD-1 Display Module provides a convenient, programmable interface to your Andover Continuum facility automation system. Authorized operators or tenants in your facility can easily arm or disarm a security zone, quickly view HVAC or security information and/or adjust personal comfort levels with little or no training.

The LD-1 Display Module includes a four-line, 16-character backlit LCD display, an audible beeper output, and a 19-button ergonomically-designed keypad, also backlit for easy data entry. With a touch of a finger, a user can scroll through building parameters such as temperatures or pressures, as well as view equipment status, change setpoints and schedules, or turn equipment on or off. The keys can be custom programmed using TAC's powerful programming language, Andover Plain English, to perform a wide variety of functions, including switching a specific zone to occupied mode, signaling an alarm condition, adjusting the amount of override time, and arming or disarming intruder alarm points, utilizing password security.

Cost-effective and compact, the LD-1 may be mounted directly on dry wall. An optional adapter plate kit is available to facilitate mounting directly on a standard electrical outlet box. The LD-1 is intended for indoor use only.

### COMPATIBILITY

The LD-1 Display Module interfaces to the Andover Continuum NetController II via the ACC-LON network with a choice of FTT-10A or RS-485 physical media. The LD-1 can co-exist with any other Andover Continuum I/O modules; for example, the UI-8-10, DI-8, AO-4-8, etc. (up to a total of 32 modules per single NetController II). Sharing one field bus reduces wiring costs while providing distributed user interfaces to your building's automation system.

### DIMENSIONAL DRAWING

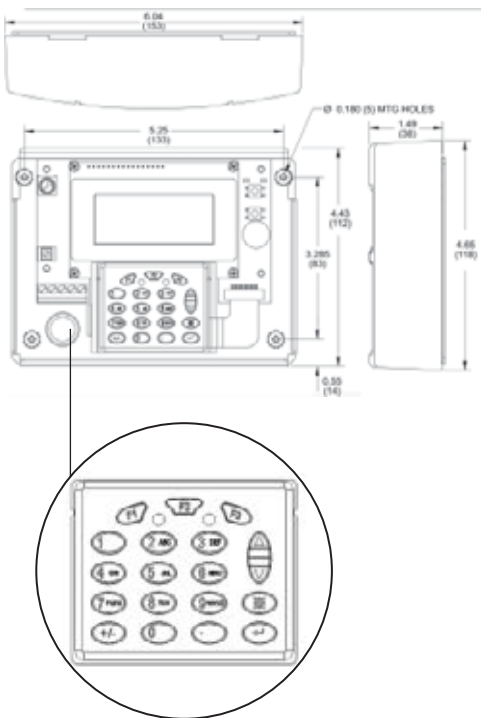

## SPECIFICATIONS

### ELECTRICAL

#### Power:

12-24 VDC, 3.0W max. (May be powered from an Andover Continuum Power Supply)

### GENERAL

#### Keypad Inputs:

19 buttons, 4 x 4 matrix, including UP, DOWN, ENTER, and CANCEL; plus 3 additional function keys, all backlit

#### Display Outputs:

4 x 16 LCD, backlit

#### Audible Beeper Output:

Yes

#### LED Indicators:

2: one Red, one Green, programmable operation

### MECHANICAL

#### Dimensions:

4.65" H x 6.04" W x 1.49" D  
(118 mm H x 153 mm W x 38 mm D)  
(outer dimensions of enclosure)

### COMMUNICATIONS

#### RS-485 Communications Speed:

39k baud

#### Bus Length:

2,000 ft. (610m)

#### Bus Media:

Shielded, twisted pair cable. 120W termination required at both ends of the ACC-LON network (when modules are mounted remotely)

#### FTT-10A Communications Speed:

78k baud

#### Bus Length:

Up to 8858 ft. (2700m) – bus topology. Up to 1640 ft (500m) – free topology

Repeater required for longer distances.

### CONNECTIONS

#### Wiring Connections:

Five-position, screw terminal block  
Single-position ground connection  
1: COMM A  
2: COMM B  
3: SHIELD  
4: VDC Return  
5: 12-24 VDC

### AGENCY LISTINGS

UL/CUL 916, FCC CFR47 Part 15, EN55022, AS/NZS 3548, Class A Emissions, CE

# Infinet II i2608/624 Local Controllers

The i2600 series controllers are designed for monitoring a small or large concentration of input points from a single controller. Choose the i2600 model with the input configuration that matches your application:

- The i2608, with eight Universal inputs, is designed for stand-alone equipment monitoring for a small concentration of input points. This controller is also configurable for Supervised Input monitoring to determine broken wire detection or shorts. The i2608 is ideal for Security applications (motion detection, glass break detection, intrusion detection) or traditional control applications (temperature, humidity, etc).
- The i2624 provides the same functionality as the i2608 and in the same small footprint of the i2608, but with three times the number of input points (24) for monitoring various device signals. With the small footprint and high point count, the i2624 is ideal for large concentration of inputs, reducing the number of controllers required in the system, and decreasing cost, complexity, and maintenance requirements.

The i2600 series also features Flash memory, increased user memory, and a fast (32-bit) processor for faster scan times, with plenty of memory available for data logging of your critical data.



## SPECIFICATIONS

### ELECTRICAL

#### Power

24VAC, 12-24VDC - auto sensing, +10% -15%, 50/60 Hz

#### Power Consumption

25 VA

#### Overload Protection

Fused with 3 amp fuse. MOV protected

### MECHANICAL

#### Size

9.03" H x 6.01" W x 2.14" D  
(229 H x 153 W x 54 D) mm

#### Weight

1.19 lbs. (.54 kg)

### COMMUNICATIONS

#### Communications Interface

Through Andover Infinet RS-485 field bus to NetController II network controller

#### Communications Speed

1200 to 19.2K baud

#### Bus Length

4,000 ft. (1,220m)

#### Bus Media

Andover Infinet: twisted, shielded pair, low capacitance cable

Supervised Alarm (single or double resistor). Current input (0 - 20 mA) using external 250 ohm resistor.

### CONNECTIONS

#### Power

3-position fixed screw terminal connector

#### Inputs

Inputs 1-8 (both i2608 and i2624): 12-position fixed screw terminal connector

i2624 only:

Inputs 9-16: 12-position fixed screw terminal connector

Inputs 17-24: 12-position fixed screw terminal connector

#### Communications

3-position removable screw terminal connector

#### Service Port

4-position shrouded connector

### AGENCY LISTINGS

UL/CUL 916, FCC CFR 47 Part 15, ICES-003, EN55022, AS/NZS 3548, Class A, CE

### DIMENSIONAL DRAWING

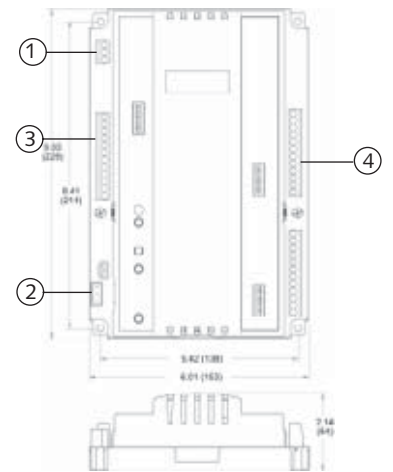

### INPUTS DRAWINGS

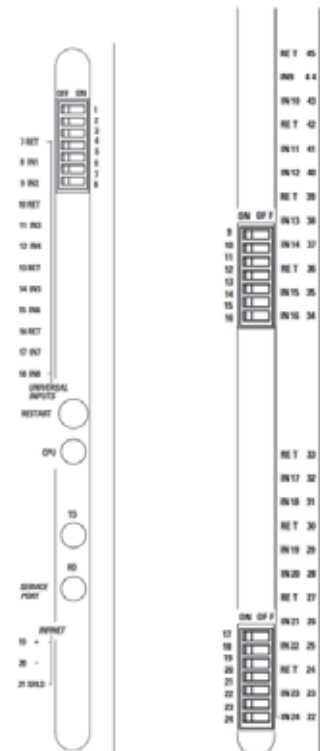

### INPUTS

#### Inputs

i2608: 8 Universal inputs

i2624: 24 Universal inputs

Voltage (0-5.115 VDC); Temperature -30°F to 230°F (-34°C to 110°C), Digital (on/off), Counter (up to 4Hz at 50% duty cycle, 125 ms min. pulse width).

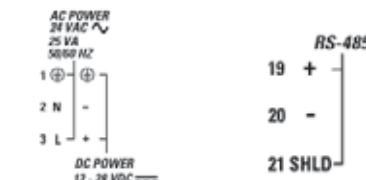

① POWER DRAWING

② COMMUNICATIONS DRAWING

③ I2608 AND I2624

④ I2624

---

Copyright © 2007, TAC  
All brand names, trademarks and registered trademarks are  
the property of their respective owners. Information contained  
within this document is subject to change without notice.  
All rights reserved.

SDS-SECURITYFAM-US  
April 2007



[www.tac.com](http://www.tac.com)

