

# Continuum™

## b-Link Repeaters

The b-Link and b-Link-F electronic repeaters are multi-port active hubs for the BACnet MS/TP field bus, designed to transmit RS-485 or fiber signals beyond the 4,000-foot (1.2 km) limitation. Andover Continuum BACnet Family controllers support the BACnet MS/TP field bus.

The b-Link accepts twisted pair cabling at each of its five RS-485 ports. A single MS/TP input supplies up to four RS-485 output signals, or “spoke.” Each spoke has the drive capability of up to 4,000 feet (1.2km) and up to 76.8K baud. A maximum of 127 devices may be attached to a single b4920 or bCX1 System Controller/BACnet Router.

For conversion applications, the same RS-485 input can become a single RS-232 output for use with third-party short haul modems. (The four RS-485 output ports are still available when using the RS-232 port.) Data transmission speeds for the b-Link are switch-selectable from 9600 to 76.8K baud.

The b-Link-F has one RS-485 port and two duplex fiber ports, and allows point-to-point chaining or stacking for use in hub applications. Using two b-Link-Fs with fiber, you can connect BACnet MS/TP directly between two buildings without the worry of electrical noise interference. Data Transmission speeds for the b-Link-F are switch-selectable from 9600 to 76.8K baud.

The b-Link and b-Link-F simplify network troubleshooting by using LED indicators. These LEDs flash to indicate when the MS/TP field bus is receiving and transmitting RS-232, RS-485 or fiber signals.

### ENCLOSURE

The b-Link is provided with a hinged, black 16-gauge, cold-rolled steel enclosure. Installation is simplified by the use of detachable connectors for all RS-485 ports or available as an open class solution without the enclosure.

### AC AND DC MODELS AVAILABLE

The b-Link is available in two models: The AC model is powered from a standard 115/230 VAC source. A 24 VDC model is also available for applications where battery-backed operation is required.

#### b-Link:

- Five-Port Active Hub for MS/TP Field Bus
- RS-485 to RS-232 Conversion for Short-Haul Modems

#### b-Link-F:

- Dual Fiber Optic Ports for Daisy Chain Configuration
- RS-485 to Fiber Optic Conversion Provides Noise-Free Communications

#### b-Link and b-Link-F:

- AC and DC Models Available
- Extends Field Bus Communications Beyond 4,000 feet (1.2km) Standard Limitation
- Switch Selectable Baud Rates from 9600 to 76.8K Baud
- AC Input Voltage Switch-Selectable
- Full LED Indication for Easy Troubleshooting

# b-Link Repeaters

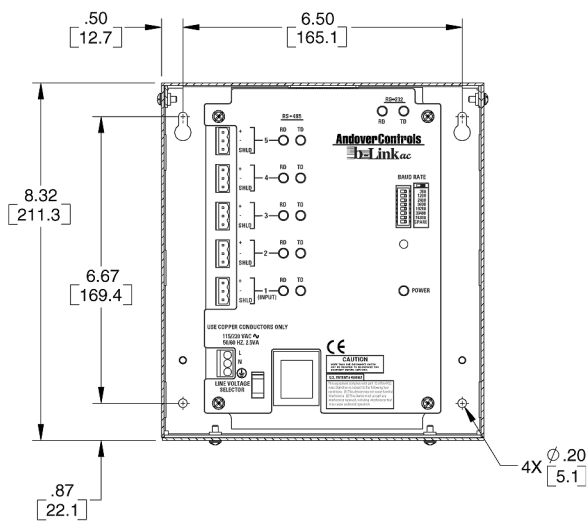
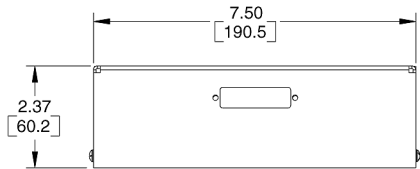

b-Link-AC with Cover Removed

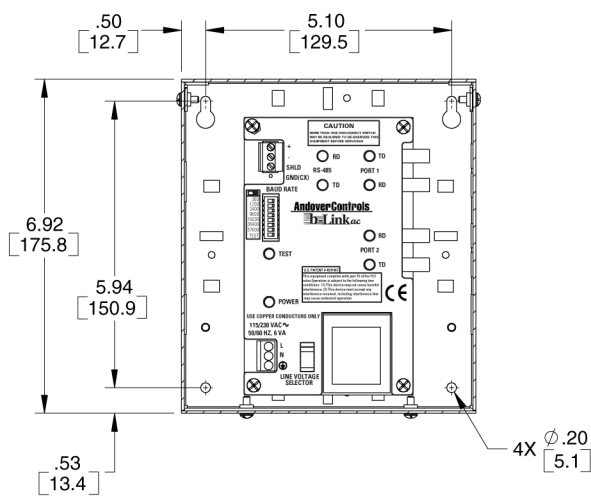
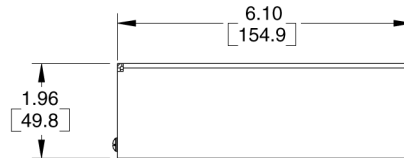

b-Link-F-AC with Cover Removed

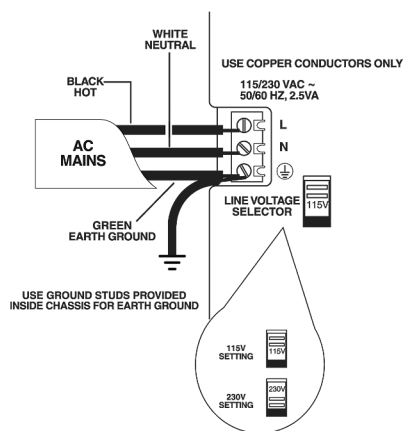

AC Power Layout

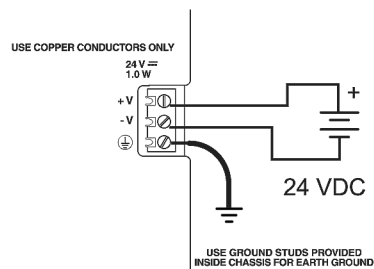

DC Power Layout

# SPECIFICATIONS

## b-Link Repeaters

### ELECTRICAL

#### Power

115/230 VAC, 50/60 Hz, switch-selectable, or 24 VDC

#### Power Consumption

6 VA for AC model; 1.8 W for DC model

#### Overload Protection

Fused with 2 A fuse. MOV protected.

### MECHANICAL

#### Operating Environment

32–120°F (0–49°C), 10–95% RH (non-condensing)

#### Size

6.92"H x 6.100"W x 1.960"D (176H x 155W x 50D)mm

#### Weight

2.74 lbs. (1.24 kg)

#### Enclosure Type

NEMA 1-style 16-GA, C.R.S. enclosure, flammability rating of UL94-5V, IP 20

### COMMUNICATIONS

#### Communications Speed

9600 to 76.8K bps, switch-selectable

#### Propagation Delay

RS-485 to fiber port = 0.5  $\mu$ s max. (not including media delay)

Fiber port to fiber port = 0.5  $\mu$ s max. (not including media delay)

#### Bus Length

RS-485 not to exceed 4000' (1.2 km). Fiber run not to exceed 12 dB fiber loss including connectors. Note: When connected in series, the maximum propagation delay from farthest node to farthest node (including media propagation delay) must not exceed 140 $\mu$ s

#### Bus Media

BACnet: twisted, shielded pair, approved, low capacitance cable

Fiber Optic: 62.5/125 duplex glass fiber optic cable

#### Pin Assignments for RS-485 to RS-232 Signal

Pin 1: Chassis Ground  
Pin 2: Transmit Data  
Pin 3: Receive Data  
Pin 4: RTS always high (9V)  
Pin 7: Signal Ground  
Pin 9: 9V/(1) 5k W  
Pin 10: 9V/(1) 5k W  
Pin 20: DTR always high

### CONNECTIONS

#### Power

AC: Three-position barrier strip  
DC: Three-position fixed terminal block

#### RS-485 Ports

Removable two-piece terminal strips

#### Fiber Optic

Two pairs of fiber optic transceiver interfaces (ST)

### USER LEDS/SWITCHES

#### Status Indicator LEDS

POWER	Power is ON
TEST	Test Mode
Fiber Optic	
PORT 1-2 TDs	Transmit Data
Fiber Optic	
PORT 1-2 RDs	Receive Data
RS-485 COMM TD	Transmit Data
RS-485 COMM RD	Receive Data

#### Switches

Test  
Baud Rate

### AGENCY LISTINGS

UL/CUL 916, FCC CFR47 part 15, ICES-003, EN55022, AS/NZS 3548, VCCI Class A, CE

### OPTIONS

AC or DC Power  
DIN Rail Kit (P/N:DIN-MTG-KIT)

Part Number	Description
B-LINK-AC	B-LINK, AC
B-LINK-AC-OP	B-LINK-AC, OPEN CLASS
B-LINK-AC-S	B-LINK, AC, SMK
B-LINK-DC	B-LINK-DC
B-LINK-DC-OP	B-LINK, DC, OPEN CLASS
B-LINK-DC-S	B-LINK, DC, SMK
B-LINK-F-AC	B-LINK, AC, FIBER
B-LINK-F-AC-S	B-LINK, AC, FIBER, SMK
B-LINK-F-DC	B-LINK, DC, FIBER
B-LINK-F-DC-S	B-LINK, DC, FIBER, SMK

Copyright © 2006, TAC  
All brand names, trademarks and registered trademarks are  
the property of their respective owners. Information contained  
within this document is subject to change without notice.  
All rights reserved.

SDS-BLINK  
2/06



[www.tac.com](http://www.tac.com)

