



# BACnet

## bCX1 Controller/Router Series

The Andover Continuum bCX1 Series is a series of Native BACnet routers and controller/routers which heads up the BACnet family of Continuum controllers. These controllers reside at the network level and route BACnet messages between BACnet/IP, BACnet over Ethernet and MS/TP networks and can serve as a BACnet Broadcast Management Device (BBMD) allowing for routing of messages between IP networks.

There are two basic bCX1 models: the bCX1-R (Router Only) and the bCX1-CR (Controller/Router). The bCX1-R model provides all the functionality to route messages between BACnet networks and the bCX1-CR is a full-function BACnet Building Controller (B-BC). The bCX1-CR performs the routing functions of the bCX1-R with the additional power of a programmable controller with expansion I/O capabilities.

### ALL BCX1 MODELS (BCX1-R AND BCX1-CR):

#### Native BACnet

As Native BACnet controllers developed in strict accordance with the ASHRAE 135-2004 BACnet standard, the bCX1 can communicate directly with other third party BACnet/IP and BACnet MS/TP devices as well as all Andover Continuum BACnet devices. The bCX1 also supports BACnet over Ethernet, allowing devices that communicate with the earlier versions of the BACnet Specification to also communicate with BACnet/IP devices.

#### Easy Configuration

The bCX1 is designed with ease-of-installation in mind. All configuration settings are done via a standard web browser – set the IP address, and save to Flash. All connections to the bCX1 series controller are accomplished with removable connectors for easy installation, providing the ability to pre-wire panels and service the unit simply. LEDs provide troubleshooting information and communication activity for all ports.

#### BBMD Support

All bCX1 Series devices can be configured to function as BACnet Broadcast Management Devices, or BBMDs. It is the BBMD's job to pass BACnet broadcasts across IP/Routers to other IP segments. As a result of having a BBMDs in place, BACnet devices are able to fully communicate via the Internet.

#### Advanced Flash Memory Management

The bCX1 Series uses non-volatile Flash memory to store the operating system and application programs. When a power loss is sensed, an on-board battery maintains all logs, trends, and other run-time data. When power is restored, both application and run-time data are restored. Memory backup or restore settings are configurable. The Flash-based operating system simplifies feature upgrades.

- B-BC — BACnet Building Controller available in Router-only and Router/Controller combo models
- Supports 18 BACnet object types including Trends, Schedules, Calendars, and Loops
- Native BACnet/IP and MS/TP communications for interoperability to third party systems
- 10/100 Ethernet port
- BACnet Broadcast Message Device (BBMD) support
- Expandable for local I/O and display using xP Expansion Modules
- Advanced Flash Memory provides utmost reliability — stores application program, operating system, and run-time data
- Flash memory allows easy online software updates
- Support for custom Embedded Web Server
- Support for BACnet Trend object
- Support for BACnet Calendar and Schedule objects
- BTL Listed B-AAC Controller with local Trends



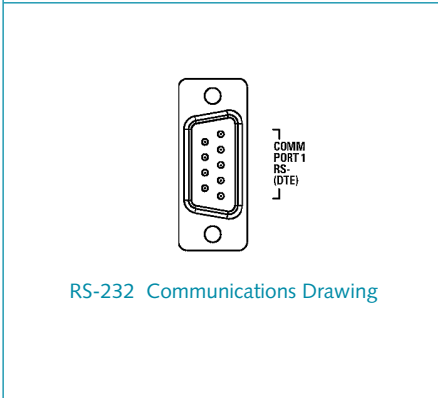
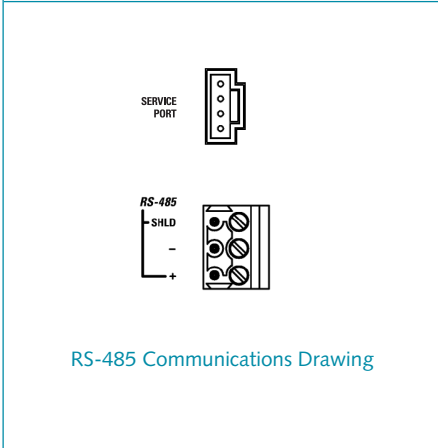
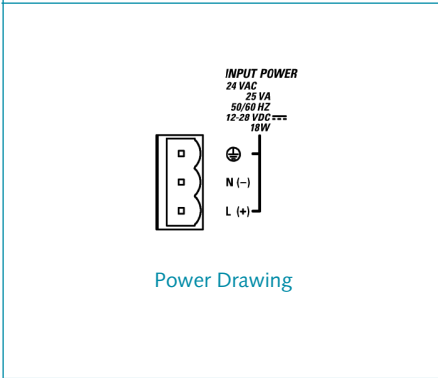
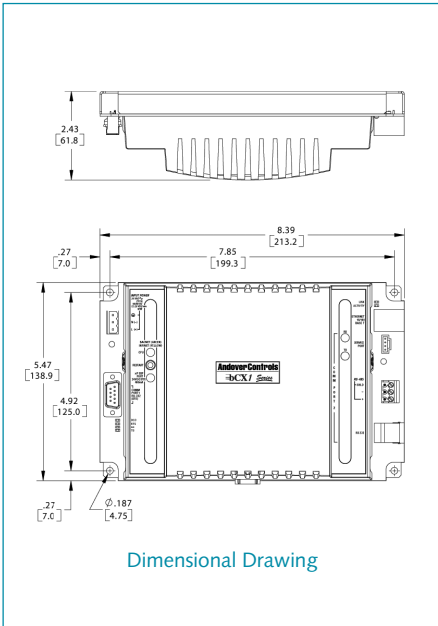

## CONTROLLER/ROUTER COMBO MODELS (BCX1-CR)

### BTL Listed BACnet Building Controller (B-BC)

The bCX1-CR is listed with the BACnet Testing Laboratories (BTL) as a BACnet Building Controller or B-BC, with interoperability BACnet Data Sharing, Alarm and Event Management, Scheduling, Trending, and Device Management.

### Programmable

The dynamic memory of the bCX1-CR can be allocated for any combination of programs and BACnet object (including Schedules, Alarms, and Trends). Our powerful Plain English programming language can directly reference any BACnet object either locally or globally. Our object-oriented Plain English, with intuitive keywords, provides an easy method to tailor the controller to meet your exact requirements. As a programmable controller, the bCX1-CR can locally support a wide range of BACnet objects, including BACnet loops, trends, and schedules. Plain English programs may be created to program coordinated control strategies, giving you the freedom to move data between third party devices that do not have peer to peer functionality provided in all Continuum controllers.

### Embedded Web Server

With the power of Plain English, standard HTML web pages can be created and embedded into the bCX1-CR to provide a simple-to-use, browser-based interface for monitoring or changing data points. The embedded web pages are fully customizable to meet any special customer requirements.

### Expansion I/O

The bCX1-CR contains an I/O expansion port for the addition of up to two xP expansion modules directly on the bottom of the controller. The xP family of modules includes the xPDI8, xPDO2, xPDO4, xPAO2, xPAO4, xPUI4 as well as the xPBD4 and xPBA4 expansion modules, which can only be used with the bCX1. In addition, the I/O bus supports the xP Local Display Module, which allows the user to view and change point values.

### SNMP Alarming Support

All bCX1 controllers are compatible with SNMP monitoring tools, which allow the controller to be interrogated for basic SNMP information. The -CR model features advanced SNMP alarm functionality as an option (-SA), providing alarm delivery for any device on the MS/TP network it manages.

Features & Models	bCX1-R	bCX1-CR
Ports	3	3
Ethernet	10/100	10/100
Comm 1	Modem	Modem, Raw Port
Comm 2	MS/TP	MS/TP, Wireless BACnet, Raw Port
Routing		
BBMD	Yes	Yes
BACnet/IP	Yes	Yes
BACnet over Ethernet	Yes	Yes
MS/TP	Yes	Yes
Wireless BACnet	Yes	Yes
MS/TP Node Options	64	0, 8, 32, 64, 127
Flash Memory	Yes	Yes
xP Expansion I/O	No	2+Display
Plain English	No	Yes
Email Support	No	Yes
Web		
Basic Configuration	Yes	Yes
Embedded Web Server	No	Yes
SNMP		
SNMP Monitoring	Yes	Yes
SNMP Alarming	No	Optional
BACnet Device Profile	Router Only	B-BC
BTL Listed	No	

# SPECIFICATIONS

## bCX1 Controller/Router Series

### ELECTRICAL

#### Power

24VAC, +10% -15%, 50/60 Hz  
12-28 VDC auto-sensing

#### Power Consumption

40 VA, 25W

#### Overload Protection

Fused with 3 amp fuse. MOV protected

#### Real-Time Clock

Battery-backed real-time clock

### MECHANICAL

#### Operating Environment

32°–120°F (0–49°C), 10–95% RH  
(non-condensing)

#### Size

Module: 5.47"H x 8.39"W x 2.43"D  
(139H x 213 W x 62 D) mm

#### Weight

Module: 1.12 lb (0.508 kg)

#### Enclosure Type

UL Open class, IP 20.  
Flammability rating of UL94-5VB

#### Mounting

Panel mount

### BATTERY

#### Battery Backup

Replaceable, rechargeable battery.  
Provides 30 days typical accumulated power failure backup of RAM memory. All data stored in Flash on power loss.

### COMMUNICATIONS

#### Communications Interface, BACnet/IP:

10/100 BaseT\*

#### Communications Interface, BACnet MS/TP:

RS-485, 127 devices max

#### Communications Interface, Wireless BACnet:

RS-485, 32 devices

#### Communications Speed, BACnet MS/TP

9600, 19.2K, 38.4k, 76.8k baud

#### RS-485 Bus Length

4,000 ft. (1,220m) standard; BACnet repeater allows extension to longer distances.

#### RS-485 Bus Media

Twisted, shielded pair, low capacitance cable

\*Note: Auto-sensing cable polarity

#### BACnet Device Profile

B-BC, BACnet Building Controller

#### BTL Listed

B-BC



### CONNECTIONS

#### Power

3-position removable screw terminal connector

#### Communications

Ethernet RJ-45

Comm1: 9-pin D-Sub - female-DTE

Comm2: RS-485 BACnet MS/TP:

Removable 3-position screw terminal connector

RS-485 Wireless BACnet:

4-position shrouded connector (Service Port)

(if RS-485 port is not used): RJ-45 8-pin (only 3 of the 8 pins are supported - RXD, TXD, GND)

#### Expansion Port

6-position shrouded connector

### USER LEDS/SWITCHES

#### Status Indicator LEDS

CPU CPU Active  
Green = BACnet

#### COMM1:

TD-232 Transmit Data-RS-232

RD-232 Receive Data-RS-232

DCD-232 Data Carrier Detect

RTS-232 Request to Send

#### ETHERNET

Link/Act  
10/100 Mbps

#### COMM2:

TD-485 Transmit Data-RS-485

RD-485 Receive Data-RS-485

#### EXPANSION

PORT PWR Power Status

#### Switches

CPU RESET

IP ADDRESS RESET

### GENERAL

#### Memory

32MB SDRAM, 16MB FLASH

#### Processor

Motorola 32-bit Coldfire, 66 MHz

#### Network Setup

Via embedded web interface

Note: bCX1 REQUIRES Continuum software v1.7 version (or later)

### AGENCY LISTINGS

UL/CUL 916, FCC CFR 47 Part 15, ICES-003, EN55022, AS/NZS 3548, Class A, VCCI, EN61000-6-1, CE

### MODELS

#### BACnet Router

BCX1-R-64

BACnet Router, 64 Node MS/TP

Support

#### BACnet Controller/Routers

BCX1-CR-0

Controller/Router, 0 Node Support

BCX1-CR-8

Controller/Router, 8 Node Support

BCX1-CR-32

Controller/Router, 32 Node Support

BCX1-CR-64

Controller/Router, 64 Node Support

BCX1-CR-127

Controller/Router, 127 Node Support

#### Options

-SA

SNMP Alarming Option

Copyright © 2006, TAC  
All brand names, trademarks and registered trademarks are the property of their respective owners. Information contained within this document is subject to change without notice. All rights reserved.

SDS-BACNET-BCX1-US  
11/06



[www.tac.com](http://www.tac.com)

